

LéOparleur Tour 2008

FACILITIES

Hello,

LéOparleur is an 8-person crew.

We need 1 double room and 3 twins in a comfortable hotel
**minimum close to the venue and 8 breakfasts

Upon their arrival, the band likes to have salads, cheese, chicken... as well as tea, coffee, beer and fruit juice.

According to the show time we will have our meal before or after the concert. We like to have 1st and 2nd courses, desert, coffee and wine.

Please take into account that two members of the band are veggies. Please avoid pork in general. Fish and beef as well as local specialties are welcome.

In the dressing room before the concert, we need a bottle of Havana Club, 25 beers -good quality, 2 bottles of good wine and 10 1.5-litre bottles of water.

For the show we need **one bottle of Pastis 1.5L** (Pernod or Ricard are OK) and 100 transparent plastic cups and 2 bottles of water, 1.5L

For venues with capacity superior to 500 people, please double these quantities.

We also need 12 small bottles of water (0.5L) and 5 towels.

Please provide a place where we can sell t-shirts and CD's with a table and chairs and the possibility to hang shirts.

We need 2 hours before the soundcheck to set up the lighting equipment and the backline on stage. The soundcheck lasts one hour and a half.

In case you could not comply, please contact us, we always find a solution.

LéOparleur Tour 2008

PATCH MICRO

Patch	instrument	micro	insert	mic stand	mon	return insert
1	kick drum	D112	gate	small	yes	gate
2	snare top	SM 57	comp	small	yes	
3	snare bottom	e 604/SM 57		small		
4	hi hat	451/SM81		small	yes	
5	percussion	e604/SM 57	comp	small		
6	tom	e 604/SM 57	gate	small		
7	floor tom	e604/SM98/421	gate	small		
8	drum	SM 57	gate	tall		
9	Drum machine	DI			yes	
10	Over Head	KM 184/451/SM81		tall		
11	Over Head	KM 184/451/SM81		tall		
12	double bass direct	DI + jack/jack	comp		yes	comp
13	double bass micro	421		small		
14	accordion	XLR (HF)	comp		yes	
15	clarinet	SM 57		small		
16	saxophone	beta 98	comp	clip	yes	comp
17	guitar AER	SM57		tall	yes	
18	guitar MARSHALL	509/SM57		small	yes	
19	vocals accordion Simon	SM58	comp	tall	yes	
20	vocals sax Maya	BETA 58	comp	tall	yes	comp
21	vocals guitar Jo	BETA 58	comp	tall	yes	
22	vocals bass Greg	SM 58		tall	yes	
23	vocals drums Eddy	SM58		tall	yes	
24	delay return					
25	delay return					
26	SPX return					
27	SPX return					
28	reverb return					
29	reverb return					
30	cd					
31	cd					
32	mixing desk mic	SM58				

updated 06 29 2006

please provide a stereo output from the mixing desk for recording purposes (e.g. a matrix)

We provide the microphones for the clarinet and saxophone and the accessories to hook them on the mic stand.

We provide one in ear monitor HF

LéOparleur Tour 2008

- **Stage** : covered, minimum size : 10 x 6 m, 1 m high.

- **PA** : adapted to the size of the venue, 3/4 active channels + subwoofers. For greater venues, please set up delayed speakers if necessary. Préférences : Adamson, L-Acoustics.

- **Main console** : 40 channels with 4-band parametric eq's, sweepable low-cut, 8 aux, 8 groups, VCAs are welcome...
Preferred models : Midas XL, Héritage, Yamaha PM 4000, PM 3500, DM2000 (please let us know...) , Soundcraft MH4, MH3.
Please avoid Spirit, Mackie etc...

- **Sound processors**: 1 stereo EQ type : DN360 Klark Teknik, GQ600 XTA or FCS960 BSS. **Please no 2031 Yamaha.**
1 Delay with **tap tempo** type : TC2290, DTWO, please no Roland SDE
1 SPX 990
1 reverb type : TC M2000, M5000, Lexicon PCM
8 compression channels type : DBX 166, BSS DPR 402/404
4 gate channels if not included with the compressors
type : DS201, DPR504
Please avoid Behringer sound processors.
1 CD player.

- **Monitor mixer** : 24 channels with parametric eq, 8 aux pre/post **minimum**. Preferences : Midas XL, Yamaha PM, Soundcraft SM

- **Monitors** : 8 identical wedges type : PS15 Nexo, MTD115 L-Acoustics including one at the monitoring console.
For stages wider than 12m, please add two equalized side-fills, thanks.
5 EQ channels type : DN360 Klark Teknik, GQ600 XTA or FCS960 BSS. **No 2031 Yamaha, thanks.**

Léoparleur Tour 2008

STAGE PLAN

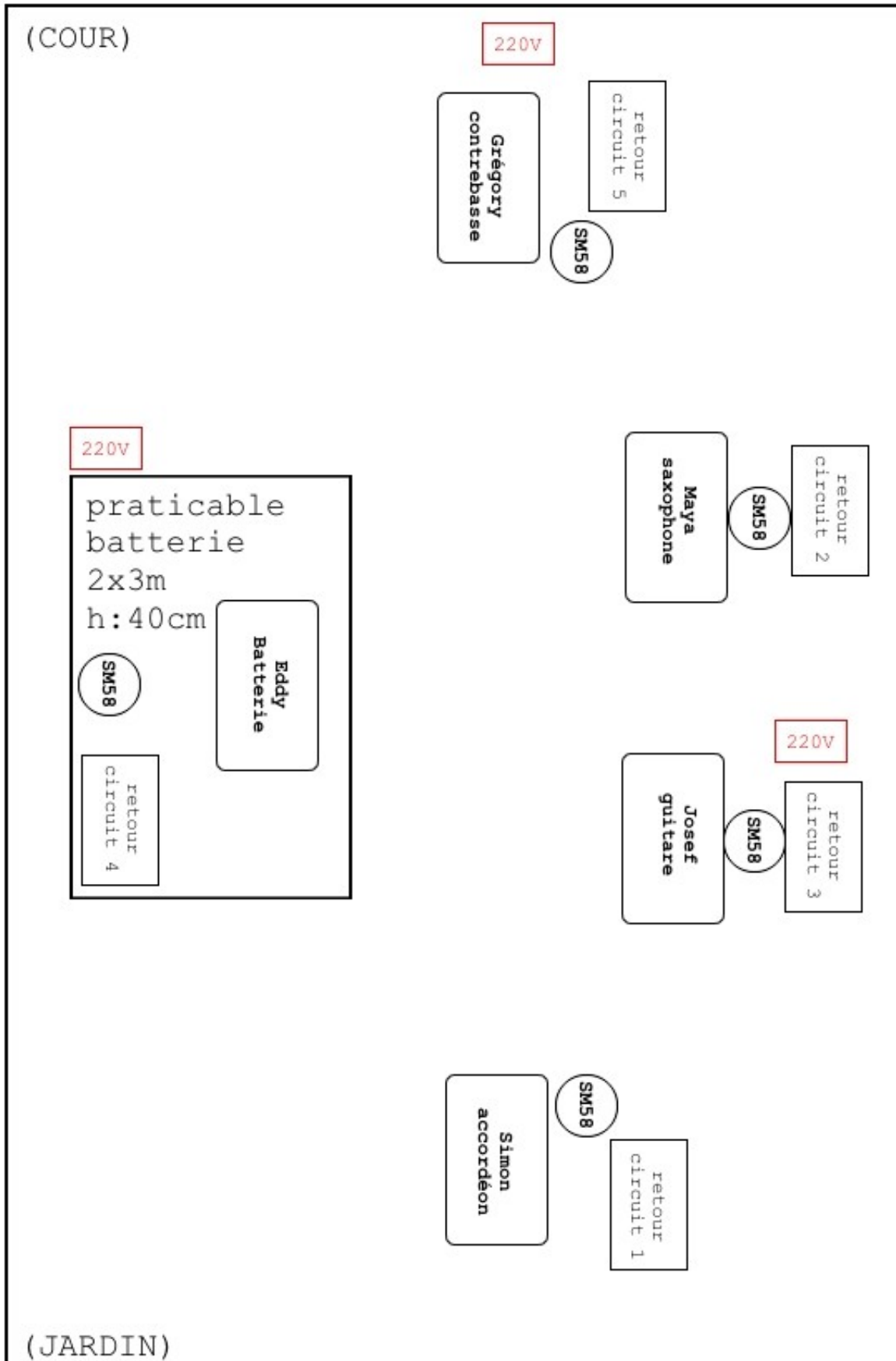

LéOparleur Tour 2008

LIGHTING

Please see the light plot (PDF file downloadable from <http://www.leoparleur.com/pro.htm>). This is a 24-channel configuration, if more are available, please contact us so that we can plan a better solution.

We provide the scroller and a LED curtain.

We need :

- 2 16A-directs on the stage.
- one 24 channel mixing desk 2 prepa type MA Lighting 24/48
- a second DMX link between the stage and the mixing desk to control the scrollers from a laptop computer.
- 5 3-meter stands Juliat or Manfrotto

PATCHLIST				
Channel	Type	Colour	Gobos	Position
1	2 x PC 1kw	L205	NO	Front
2	2 x PC 1kw	L205	NO	Front
3	1 x PC 1kw	L205	NO	Front
4	1 x PC 1kw	L205	NO	Front
5	1 x PC 1kw	L205	NO	Front
6	1 x ParCP62	scroller	NO	Floor
7	1 x ParCP62	scroller	NO	Floor
8	1 x ParCP62	scroller	NO	Floor
9	2 x ParCP62	scroller	NO	Floor
10	3 x Horiziodes	Nc	NO	Floor
11	2 x Horiziodes	Nc	NO	Floor
12	1 x Découpe	Nc	NO	Back
13	1 x Découpe	Nc	NO	Back
14	1 x Découpe	Nc	NO	Back
15	1 x Découpe	Nc	NO	Back
16	1 x Découpe	Nc	NO	Back
17	2 x ParCP61	L165	NO	Back
18	2 x ParCP61	L165	NO	Back
19	2 x ParCP61	L020	NO	Back
20	2 x ParCP61	L020	NO	Back
21	3 x Découpes	Nc	Yes	Back
22	3 x Découpes	Nc	Yes	Floor
23	2 x ParCP62	scroller	NO	Floor
24	LED Curtain	Blue	NO	Back
Total	PC 1kw	x 7		
	Découpe 15/42°	x 11		
	ParCP61	x 8		
	ParCP62 type <u>Thomas</u>	x 7		
	ACP 1001	x 5		
	Dimmers	24 x 3kw		

Lighting engineer : Stéphane + 33(0)6 09 43 43 21.

Contact : +33 (0)6 77 75 68 87. info@leoparleur.com
 Léo Productions 105 rue de la plaine des bouchers 67100 Strasbourg
www.leoparleur.com